

UP TO PAINT

UTP.P | UTP.P.AP | UTP.E | UTP.E.AP | UTP.P.R

SOLLEVATORE PER ZONE DI PREPARAZIONE E CABINE DI VERNICIATURA

LIFT FOR SPRAY BOOTHS AND PREPARATION AREAS



UTP.P

Up to paint con pompa e braccetti manuali
Up to paint with pump and manual arms

UTP.P.AP

Up to paint con pompa e braccetti automatici
Up to paint with pump and automatic arms



UTP.P.R

Up to paint con pompa e rampe
Up to paint with pump and ramps

UTP.E

Up to paint con centralina e braccetti manuali
Up to paint with power unit and manual arms

UTP.E.AP

Up to paint con centralina e braccetti automatici
Up to paint with power unit and automatic arms

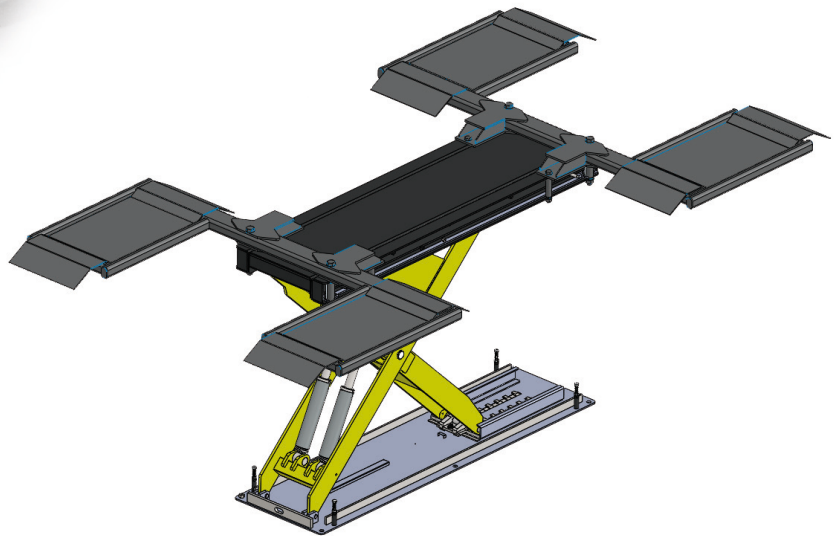

Optional

DISPONIBILI RIALZI PER INSTALLARE IL SOLLEVATORE SU OGNI TIPO DI FONDAZIONE
RAISERS AVAILABLE TO INSTALL THE LIFT ON ANY TYPE OF FOUNDATION

UTP.R

VASCA DI CHIUSURA FOSSA
PIT CLOSURE TANK







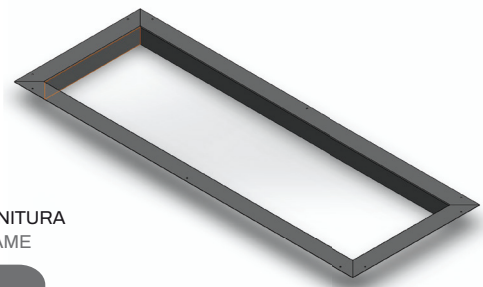



UTP.08

CORNICE DI FINITURA
FINISHING FRAME

UTP.C



Caratteristiche tecniche | Technical features

 PESO / WEIGHT	400 kg	 LARG. MIN / MIN WIDTH	600 mm
 LUNGHEZZA / LENGHT	1990 mm	 POMPA / PUMP	400 bar
 ALT. MAX / MAX HEIGHT	1000 mm	 PORTATA / CAPACITY	3000 kg 2700 kg (con rampe with ramps)
 ALT. MIN / MIN HEIGHT	260 mm	 TAMPONE / BUFFER	60 mm
 LARG. MAX / MAX WIDTH	1750 mm	 IMBALLO / PACKAGING	2000 x 1200 x 700 mm